

*The simplest ideas are often the best*

## **‘Chemflo’ Range**

Virgin PTFE and Anti-static PTFE air-operated double diaphragm pumps ideal for hazardous materials



## Flotronic's range of Chemflo pumps

### Chemflo pumps - when the safe transfer of hazardous liquids is paramount

Chemflo pumps have been specifically designed to handle hazardous materials including aggressive chemicals. Crucial to the design is an outer Stainless Steel housing which supports and protects the PTFE main pump body through a range of pressure and temperature variations. This ensures a perfect seal is retained under all conditions.

### Ideal for chemical, pharmaceutical and similar industries

Flotronic's unique 'ONE-NUT' concept is particularly useful given the Chemflo's likely applications. The 'ONE-NUT' design is a fast-maintenance concept that turns the conventional pump inside out. Fluid passes between the diaphragms directly through the centre of the pump with air pressure operating on the outside. The pump is held together by one nut on the side opposite the external air valve. 'ONE-NUT' allows in-line inspection/replacement of diaphragms in less than 15 minutes.

The outer metal housing is a further reason for the Chemflo's extensive use in the chemical and pharmaceutical industries. Others include the Chemflo's ability, as an air-operated pump, to self-prime, 'dry-run', dead-head and handle solids.

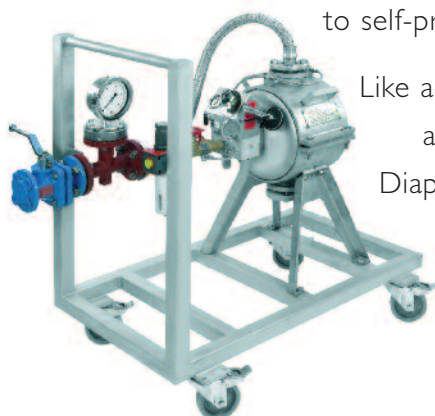

Like all Flotronic pumps, the Chemflo can be customised to suit any application or location. With environmental protection in mind, Diaphragm Rupture Protection and fully pneumatic Alarm Systems can be fitted. A range of accessories is also available including Pneumatic Pulsation Dampers and Batch Control Counters.

An optional 2 or 4 wheeled trolley with guide handle makes the Chemflo easily transportable.

Flotronic's commitment to high quality management of the processes that create and control our products has been recognised in the achievement of the ISO 9001 accreditation, the internationally recognised standard for quality management of businesses.

*Flotronic 'One - Nut' pumps - The simplest ideas are often the best*



# Flotronic 'Chemflo'

## The impressive features and benefits of the Chemflo range:

- self-priming, suction lifts (3.6m/12ft dry and 8m/26ft wet)
- can run dry
- able to stop/re-start against closed/open valve without pressure relief or damage
- ease of maintenance through Flotronic Pumps' 'ONE-NUT' technology
- easy air valve maintenance when pump is in-line
- a range of ½" to 3" connections
- ATEX 94/9/EC compliance up to Gas Group IIC
- optional diaphragm rupture detection system with instant pump shut-down alarm facility to keep product contamination-free
- optional high temperature diaphragm allows for a 135°C (275°F) maximum operating temperature
- air valves available in Polypropylene, PTFE, Stainless Steel and Aluminium
- a range of connections include ANSI/DIN/BS flanges with PTFE raised face as standard. Other connections can be supplied on request
- latest designs eliminate the costly internal air mechanisms normally associated with Double Diaphragm Pumps - and with no requirement for lubrication
- material certification available on request (eg: 2.2 on wetted components).

## All of which help you to:

- maintain levels of safety in hazardous environments and operations
- reduce down time and cleaning costs
- keep operations running and cost-efficient.

## Applications:

- Chemical, pharmaceutical and similar industries
- Pilot plants (often in sampling lines)
- As emergency pumps for hazardous chemical recovery.

### Optional construction materials:

#### Wetted Parts

**Body:** PTFE or anti-static PTFE

**Thrust Tube:** PTFE or anti-static PTFE

**Diaphragms:** PTFE or anti-static PTFE faced with Nitrile and EPDM backing as required

**Divider Seals:** PTFE

**Balls:** PTFE or EPDM

**Seats:** PTFE or anti-static PTFE

#### Non-wetted parts

**Housing:** Stainless Steel

**Air Valves:** PTFE, Stainless Steel, Polypropylene and Aluminium

# Technical Data

## Flow Rate 10" diameter diaphragm 1"

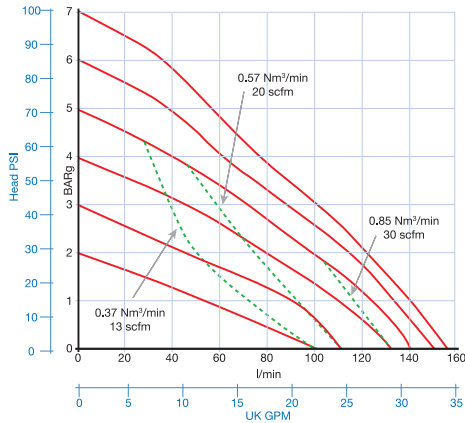

## Flow Rate 14" diameter diaphragm 3"

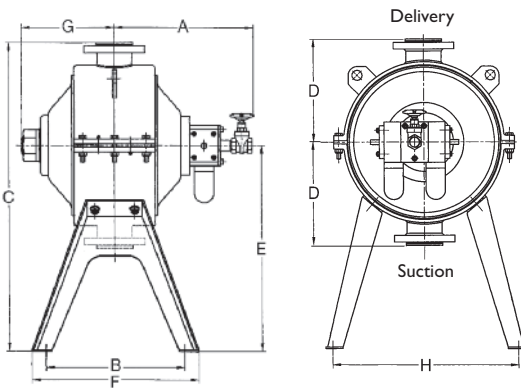
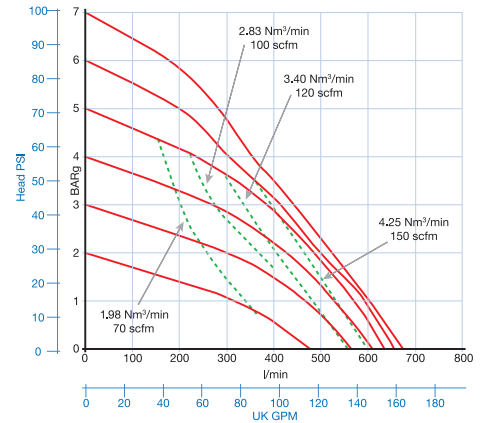

'Chemflo' Virgin & Anti-Static PTFE										
Size	A	B	C	D	E	F	G	H	Wt/kg	Diaphragm Diameter
1"	240	235	550	180	370	300	140	325	38	10"
1½"	240	235	550	180	370	300	140	325	40	10"
2"	240	250	570	180	390	315	140	345	42	10"
2"-3"	350	350	780	260	520	420	235	470	100	14"

Dimensions in mm

Maximum operating pressure 7.2 bar (105 PSIG)

Flotronic Pumps Limited.  
Ricebridge Works, Brighton Road, Bolney, West Sussex RH17 5NA. UK  
Tel: +44 (0)1444 881871 Fax: +44 (0)1444 881860  
E-mail: sales@flotronicpumps.co.uk Web: www.flotronicpumps.co.uk  
For authentic Flotronic pump spares go to: www.flotronicspares.co.uk

'Flotronic' is a UK registered trade mark.

Specifications subject to change without notice.



ATEX APPROVED PUMPS

